



1. Dual-Temp system
2. big capacity countertop
3. Energy Saving
4. Easy Maintenance



Principle

Bakers Rock H-Series electric model conveyor ovens, is composed of one or more stackable baking chambers and an optional stand. During baking, the product is placed on the stainless steel 304 conveyor belt and passes through two flows of hot air : **impingement technology** , the best system for heat distribution in the whole baking chamber for perfect baking of pizza, pastry, seafood, sandwiches, bagels, ethnic foods and more. Management of needed power is automatic according to the load.

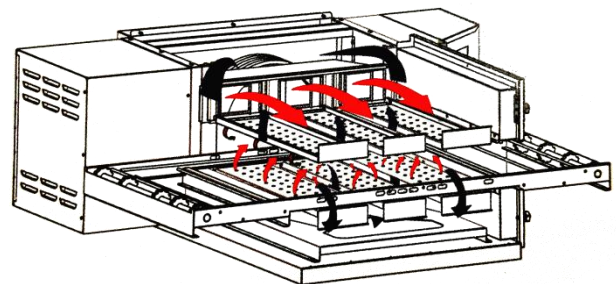

Standard Features

- Patented EMS Energy Management System reduces energy consumption and increases cooking efficiency
- Patented “Jet Sweep” impingement process that delivers constant heat to the chamber
- Adaptive power technology for that generate heat only when need (Eco-mode)
- 365*105mm Front-loading window with cool handle
- 20”(41cm) wide by 44” (112cm) length conveyor belt
- 24”(61cm) long baking chamber
- LCD control panel more easy to operate and more accurate bake time / conveyor speed
- Stainless steel front, sides, top and interior
- 12”(304.8mm) Extension Tray
- Floor space 1165*1049mm
- Reversible conveyor direction

Optional Features

- Stand with casters
- Extended warranty available

Conserves Energy

Unit incorporates a patented Energy Management System. QiangAn ovens provide very efficient heat transfer to product. Energy is conserved as air is recycled from heater to product, with minimum loss. Oven is cool to the touch.

Cleanability

H2024 Ovens are designed for easy cleaning. Removable parts include: crumb pans, end panels, air fingers, exit tray, conveyor belt.

Easily Services

Control compartment is designed for quick and easy access.

Warranty

2 years free parts and Lifelong online technical support.

Ventilation

Use of a ventilation hood is strongly recommended.

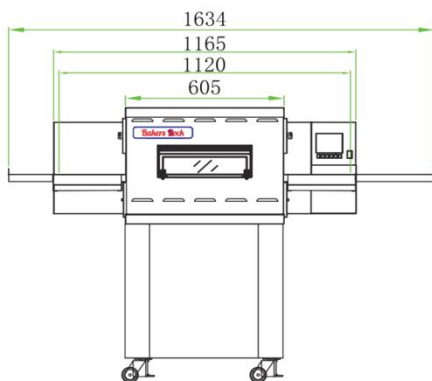

(Front)

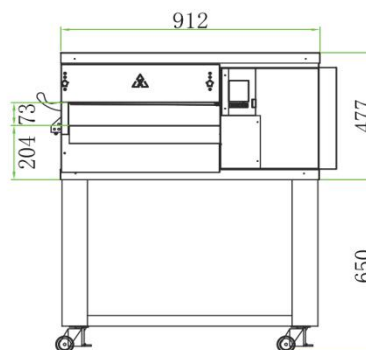

(Side)

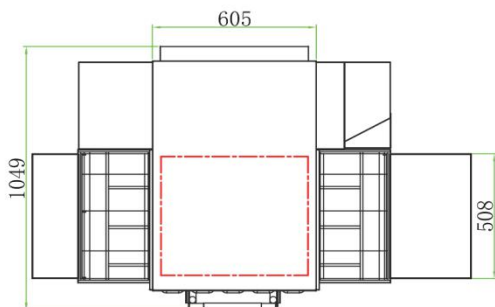

(Top)

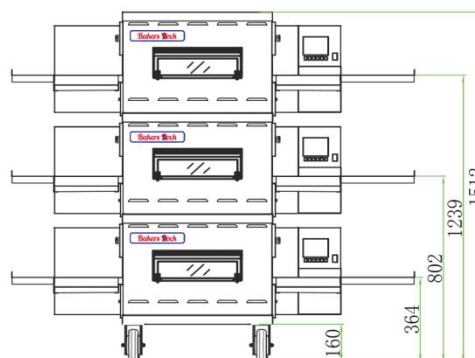

(Stack)

GENERAL INFORMATION

TYPE	VOLTAGE	PHASE	FREQUENC Y	RATED HEAT INPUT	AMPERAGE				SUPPLY	BREAKERS
					L1	L2	L3	N		
H2024	220V	1	50/60 Hz	10.1kW	0.0	-	-	0.0	2 pole 3 wire (L+ N+G)	As per local code
	220V	3	50/60 Hz		0.0	0.0	0.0	-	3 pole 4 wire (3L+ G)	As per local code
	380V	3	50/60 Hz		0.0	0.0	0.0	1.8	4 pole 5 wire (3L+N+ G)	As per local code

* Ship Info. : Data of package with plywood case

* Capacity : 4m 50s bake time , 245°C , per hour , pizza or other round products

ALL SPECIFICATIONS SUBJECT TO CHANGE WITHOUT NOTICE.