



CATALOG 2026

QIANG'AN  
FOODSERVICE EQUIPMENT



Specialty  
Creates Value



**Headquarter:**

Shanghai Qiang'An FoodService Equipment Co., Ltd.  
Tel: 021-52380580 / Fax: 021- 52381566  
Web: [www.qiangan.net](http://www.qiangan.net) / [www.bakers-rock.com](http://www.bakers-rock.com)  
Add: Bldg B, No.1439, Wuzhong Rd. 201103 Shanghai CN.

**Manufacturer :**

Qiang'An FoodService Equipment (Nangtong) Co., Ltd.  
Bldg 1, No.2 Heshunzhong Rd. Hai'an City, 226600 Nantong CN.

Shanghai Qiang'An FoodService Equipment Co., Ltd.



**26 YEARS**  
TOP BRAND OF CHINA  
SPECIALIZED IN CONVEYOR OVEN

**Authentication  
& Certificates**



**Application  
Scenario**

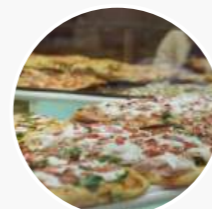

Bakery Store



Bar

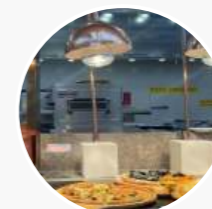

Cafeteria



Pizzeria



Restaurant

## About QiangAn

Established in 2001. The own subordinate manufacturer: QiangAn Kitchen Technology (Nantong) Co., Ltd., which is awarded as provincial high-tech enterprise located in Nantong, Jiangsu Province. The company has more than 100 employees with eight-person R&D teams. We specialize in production and sales of commercial air impingement conveyor pizza ovens, obtained 31 product related invention patents.

With 26 years of continuous development, QiangAn has become a well-known brand in China, annual production 5,000+ units, accumulative total provided quality services for four thousand more restaurants, hotels, cafeterias and schools. But we remain committed to technical innovation & breakthrough of ovens and keeping 1-2 new products launched every year. At the same time, we have a professional chef team to develop more applications of the pizza oven to satisfy the variety demands of the market.

After great success in the domestic market, the company has set its sights on overseas markets. So we set up a new brand "Bakers Rock" and built a professional foreign trade team in 2020 to serve every overseas customer better. At present, our product has been exported to the United States, Russia, France, Ireland, Serbia, Saudi Arabia, Kuwait, the United Arab Emirates, South Africa, Malaysia, Bangladesh, New Zealand, Japan, Venezuela and other countries.

■ We firmly believe that "Specialty creates value", to provide customers with more professional & reliable and maintenance-free equipment is our mission.

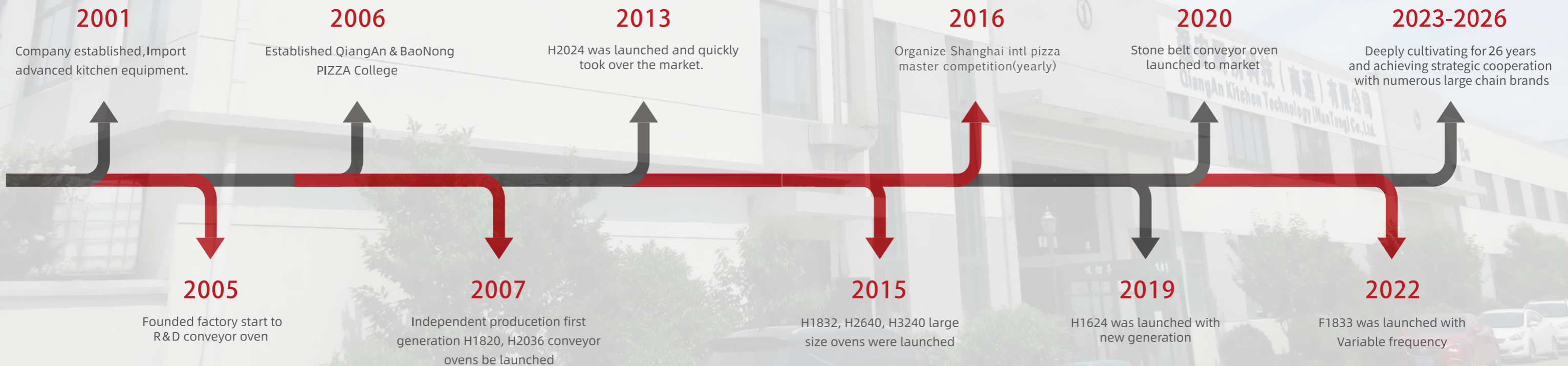

# Conveyor Oven

## BAKERS ROCK



Air Impingement Technology Efficiently lock the moisture in food, Advanced hot air circulation system save energy consumption.

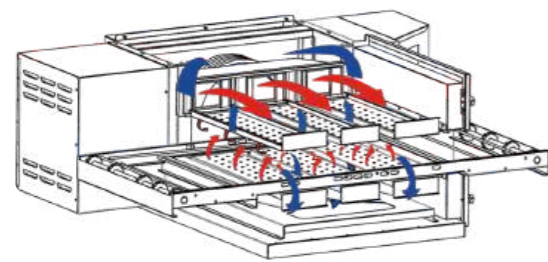

Simple & convenient operation , labor saving, standardized production Adjusts the time and temperature to cook a variety of foods by Intelligent LCD controller without chef experience.



Equipped ECO mode, efficient energy use, income is obvious Help to reduce energy consumption when kitchen is suspend.



The equipment is composed of strong stainless steel shell and deep insulation layer, with long-term operation without deformation tolerance , with better food safety.



A variety of different size models are optional , all stackable.

# Conveyor Oven



Gas Conveyor Oven



G2028

G2028 (Gas)	
Setting Time	1.5-20min(adjustable)
Gas Consumption	0.42m <sup>3</sup> /LPG 0.95m <sup>3</sup> /Natural gas
Max.Temp	350°C
Heating Area(W*L)	20*(480mm)*28*(710mm)
Overall Size	1540*1064*480(mm)
Overall (With Extension Tray)	1675*1064*480(mm)
Max.Inlet Height	82mm
Floor Space	1.67m <sup>2</sup>
Voltage	220V ±10%
Electric Current	1.4A
Power	0.3kW
N.W.	150Kg
Suitable for	Small And Medium-sized Pizza Shops, Coffee Shops,Western Restaurants
Applied to	Pizza,Snack,Steak,Cheese baked rice & Noodles,Dessert



Window Design



G3240

G3240 (Gas)	
Setting Time	2-30min(adjustable)
Power Consumption	0.91 m <sup>3</sup> /LPG 2.72 m <sup>3</sup> /Natural gas
Max. Temp	320°C
Heating Area(W*L)	32*(815mm)*40*(1036mm)
Overall Size (W*D*H)	2036*1440*649 (mm)
Overall (With Extension Tray)	2239*1440*649 (mm)
Max. Inlet Height	82mm
Floor Space	3.22m <sup>2</sup>
Voltage	220V±10%
Electric Current	3.2A
Power	0.7kW
N. W.	365kg
Suitable for	Medium Large-sized Pizza Shops, Coffee Shops,Western Restaurants
Applied to	Pizza,Snack,Steak,Cheese baked rice & Noodles,Dessert

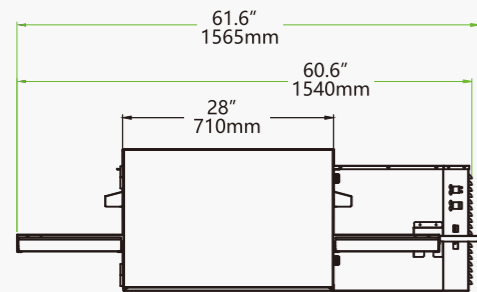

(Main View)

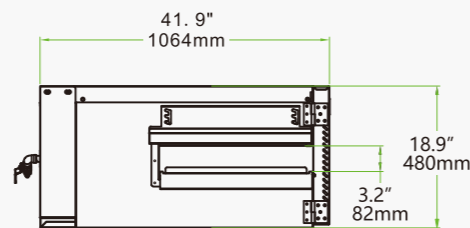

(Side View)

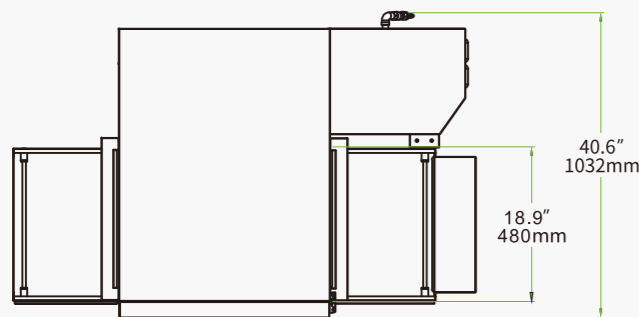

(Top View)

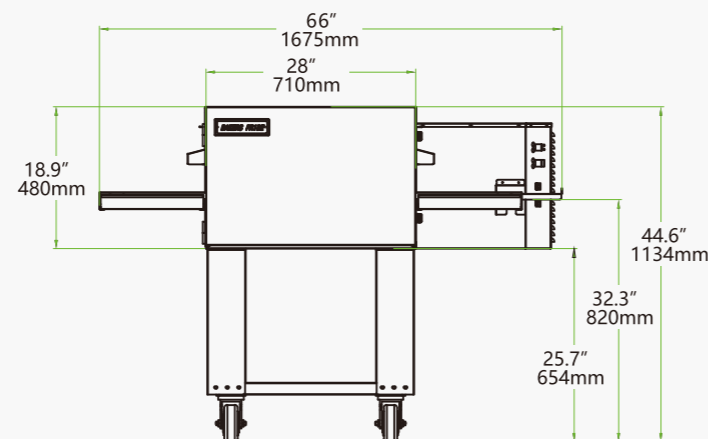

(Stackable)

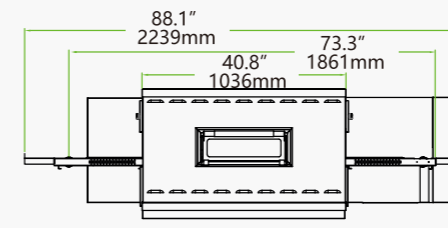

(Main View)

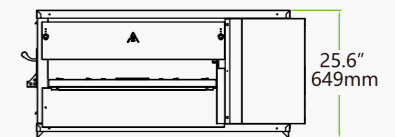

(Side View)

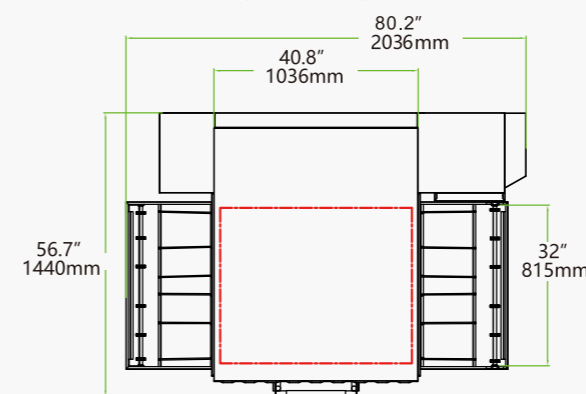

(Top View)

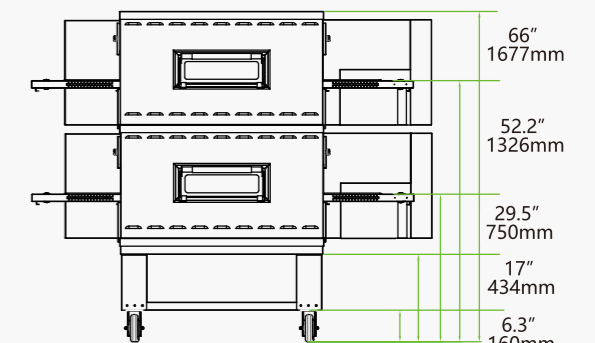

(Stackable)

# Stone Conveyor Oven



### Expandable Capacity

The stackable design allows you to stack up to three units, tripling your output.

### Dual-Temp. System

Independent baking ceiling and baking floor temperature control system with adjustable conveyor belt speed guarantee excellent cooking results of any sort of food.

### Cook up to 18" Pizza

We adopted a true 18 inch wide belt so you can put standard large pizza trays, unlike some of the competing conveyor ovens on the market.

### Crumb-Collecting Tray

Removable Crumb-collecting tray for easier cleaning and maintenance.

### Refractory Stone Fillets

We innovatively adopted refractory stone fillets instead of traditional stainless steel conveyor belt, plus up to 450°C operating temperature, can cooked classic Italian pizza.

Test data shows that the capacity has a 70% increased compared to traditional conveyor oven of the same size. Cook more pizza per hour means less equipment investment.

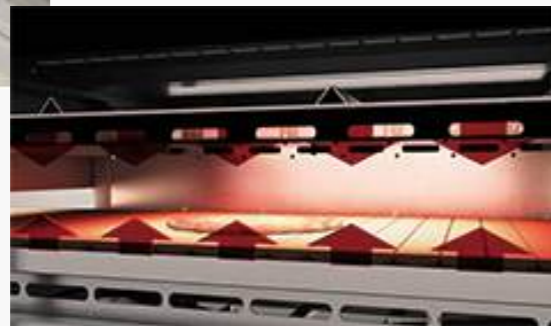
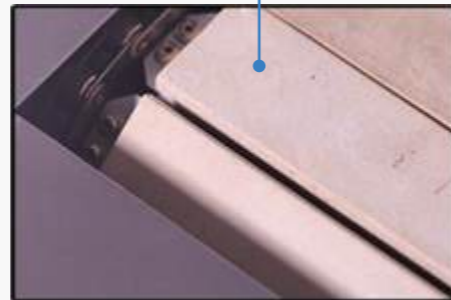

S1832 (Electric)	
Setting Time	50s-18min(adjustable)
Power Consumption	9-12kW/hr
Max.Temp	450°C
Heating Area(W*L)	18"(460mm)*32"(800mm)
Overall Size	1874*1065*524(mm)
Overall (With Extension Tray)	2138*1065*524(mm)
Max.Inlet Height	102mm
Floor Space	2.28m <sup>2</sup>
Voltage	380V+10%
Electric Current	19.5A
Power	13kW
N.W.	200kg
Suitable for	Pizza chain,Western Restaurant
Applied to	Pizza,Snack,Steak,Cheese baked rice& Noodles ,Dessert

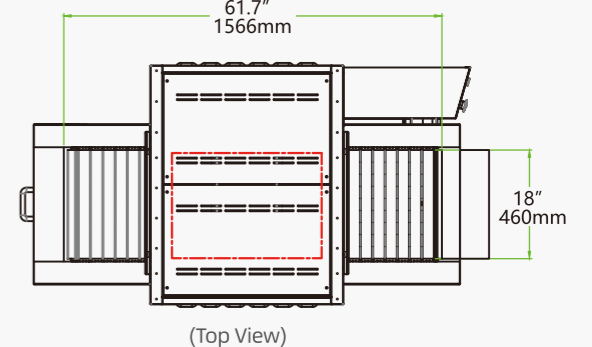
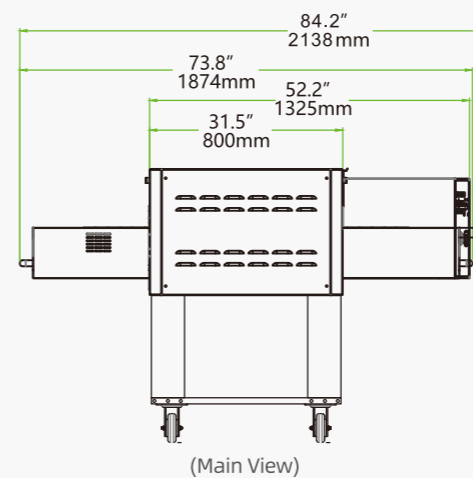
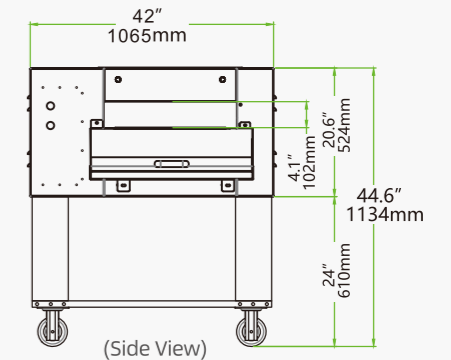

# Stone Conveyor Oven



Super Productivity



CL3240+S3240

# BAKERS ROCK

S3240	
Setting Time	1.5-18min(adjustable)
Power Consumption	15-21kW/hr
Max. Temp	450°C
Belt Size (W*L)	1946mm*815mm
Heating Area	32"(815mm)*40"(1036mm)
Electric Current	44.1A
Voltage	380V±10%
Rated Power	29kW
Max. Inlet Height	100mm
N. W.	380kg
Overall Size (W*D*H)	2173*1405*524(mm)
Overall (With Extension Tray)	2411*1405*524(mm)
Suitable for	Pizza Chain, Pizza Factory, Baking Factory
Applied to	Pizza,Frozen Pizza,Pre-Cook Pizza Base, Burger,Tacos,Pork Jerky,Dried Vegetables

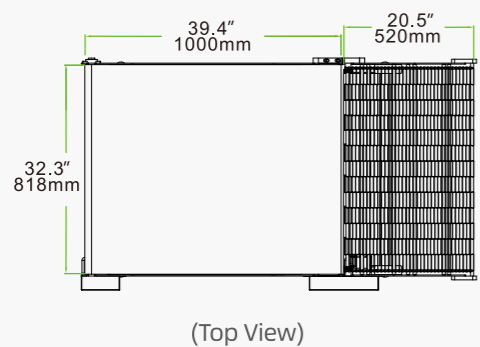
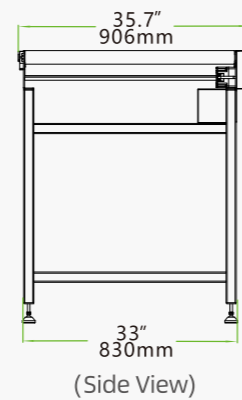
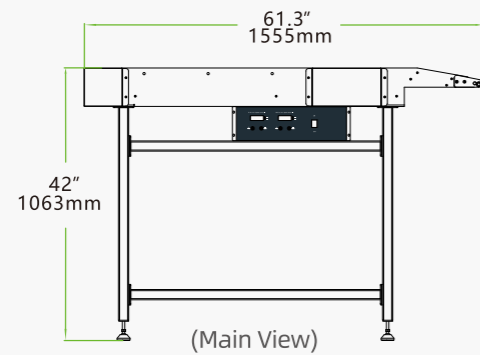

CL3240	
Conveyor speed range	40s-18min/1036mm
Belt width	818mm("32-inch")
PU Belt length	1000mm
SUS mesh belt length	520mm
Overall dimension	1555*906*1063(mm)
Voltage	220V/1ph
Frequency	50Hz
Rated power	50w
Applicable place	Link to S3240(oven)

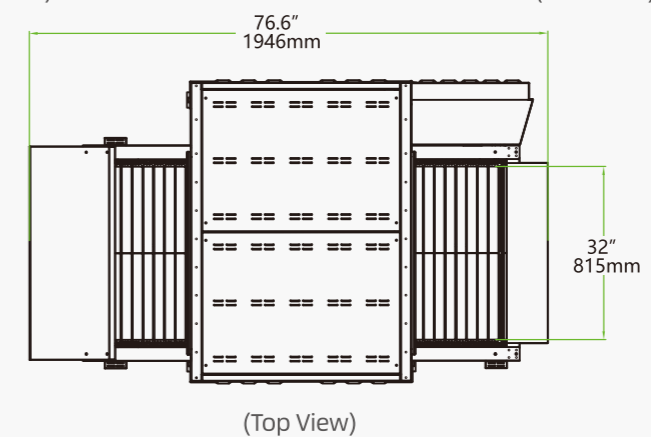
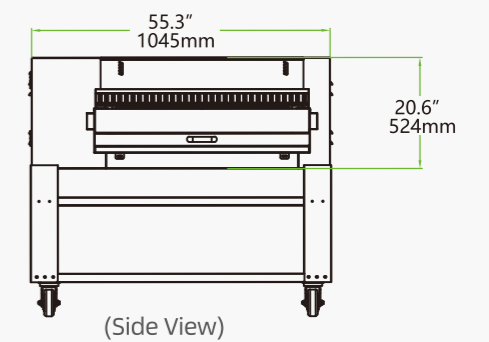
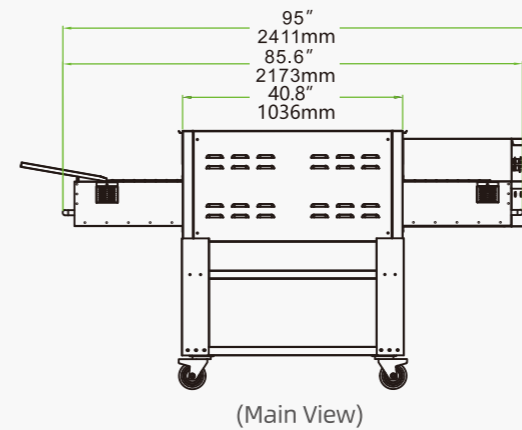

# Countertop Conveyor Oven

**BAKERS ROCK**



Dual.Temp Control System



H1624pro

H1624Pro (Electric)	
Setting Time	1.5-15min(adjustable)
Power Consumption	3.5-4.5 kW/hr
Max.Temp	320°C
Heating Area(W*L)	16" (410mm)*24" (600mm)
Overall Size	1215*850*481(mm)
Overall (With Extension Tray)	1600*850*481(mm)
Max.Inlet Height	85mm
Floor Space	1.36m <sup>2</sup>
Voltage	220V/380V+10%
Electric Current	10A/30A
Power	6.8kW
N.W.	120Kg
Suitable for	Pizza chain,Cafe, Western Restaurant
Applied to	Pizza,Snack,Steak, Cheese baked rice,Dessert



Hot Sale



H2024

H2024 (Electric)	
Setting Time	1.5-20min(adjustable)
Power Consumption	4.5-5.5kW/hr
Max.Temp	300°C
Heating Area(W*L)	20" (480mm)*24" (605mm)
Overall Size	1165*1049*477(mm)
Overall (With Extension Tray)	1634*1049*477(mm)
Max.Inlet Height	71mm
Floor Space	1.7m <sup>2</sup>
Voltage	220V/380V+10%
Electric Current	15A/45A
Power	10.2kW
N.W.	140Kg
Suitable for	Pizza Delivery Shop,Western restaurant,Chain Supermarket
Applied to	Pizza,Snack,Steak, Cheese baked rice,Dessert

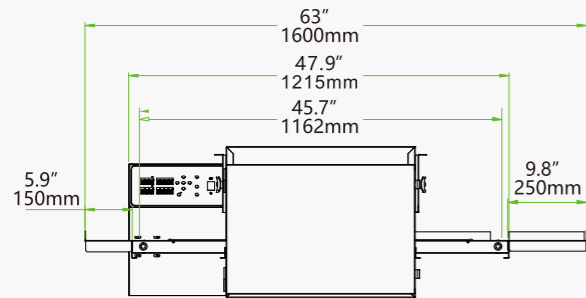

(Main View)

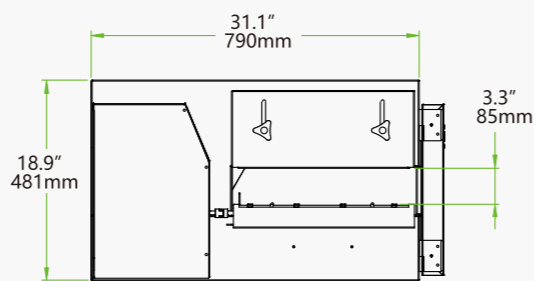

(Side View)

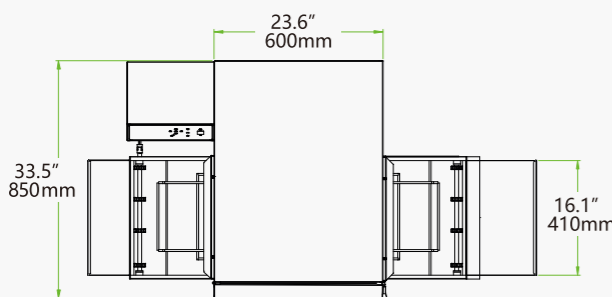

(Top View)

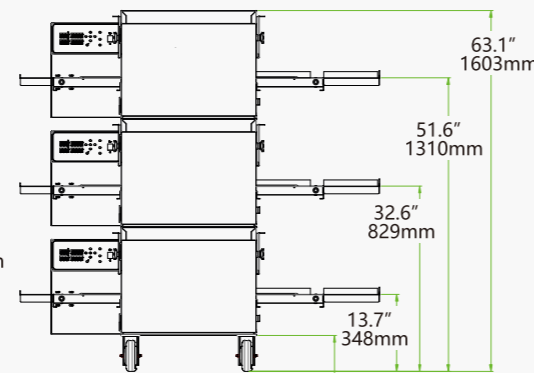

(Stackable)

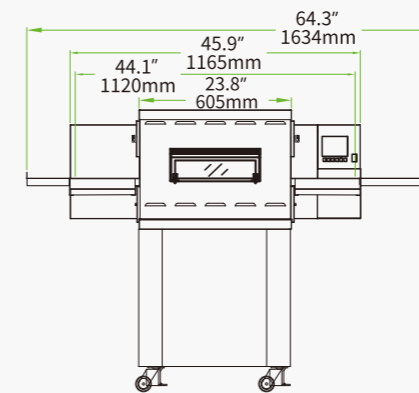

(Main View)

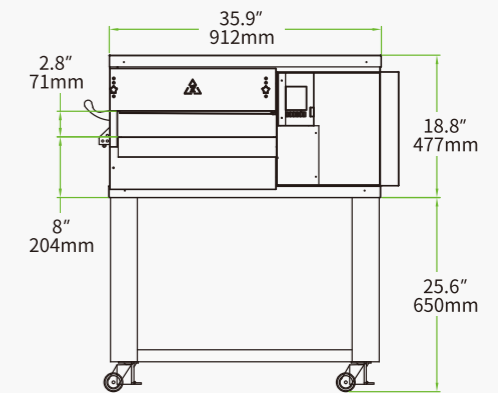

(Side View)

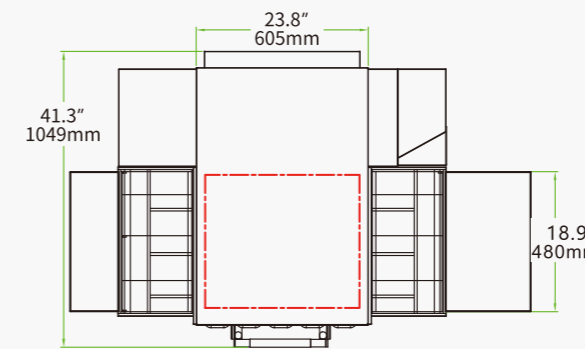

(Top View)

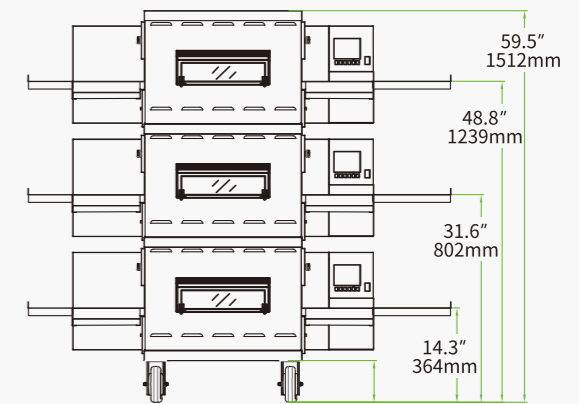

(Stackable)

# Conveyor Oven



Customize Menu



F1618

F1618 (Electric)	
Setting Time	35s-15min(adjustable)
Power Consumption	4.5kW/hr
Max. Temp	315°C
Heating Area(W*L)	16*(397mm)*18*(475mm)
Overall Size (W*D*H)	917*774*358(mm)
Overall (With Extension Tray)	1225*774*358(mm)
Max. Inlet Height	80mm
Floor Space	0.95m <sup>2</sup>
Voltage	380V±10%
Electric Current	11.4A
Power	7.7 kW
N. W.	80kg
Suitable for	Small and Medium-sized Pizza Shops, Coffee Shops, Western Restaurants
Applied to	Pizza, Snack, Steak, Cheese baked rice & Noodles, Dessert

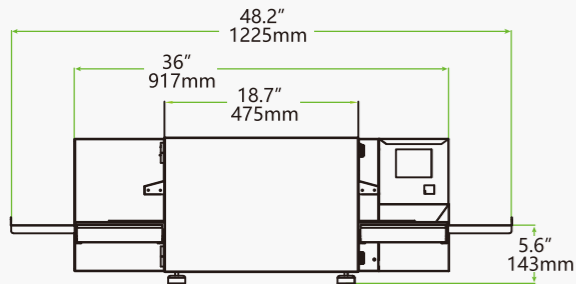

(Main View)

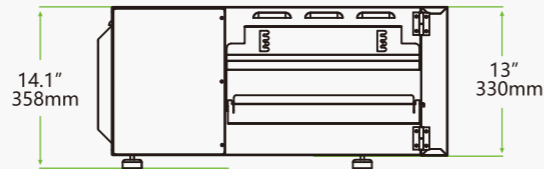

(Side View)

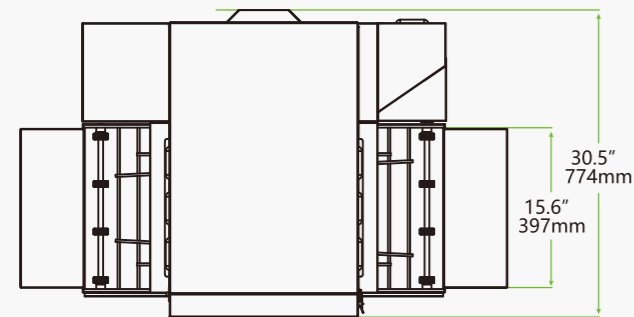

(Top View)



(Stackable)

# BAKERS ROCK



Variable Air Power



F1833

F1833 (Electric)	
Setting Time	1.5-25min(adjustable)
Power Consumption	3.7-6kW/hr
Max.Temp	350°C
Heating Area(W*L)	18*(460mm)*33*(840mm)
Overall Size	1512*878*521(mm)
Overall (With Extension Tray)	1645*878*521(mm)
Max.Inlet Height	74mm
Floor Space	1.44m <sup>2</sup>
Voltage	380V ±10%
Electric Current	18A
Power	12.8kW
N.W.	180Kg
Suitable for	Pizza chain,Cafe,Western Restaurant
Applied to	Pizza,Snack,Steak, Cheese baked rice,Dessert

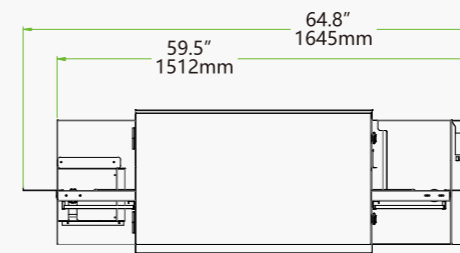

(Main View)

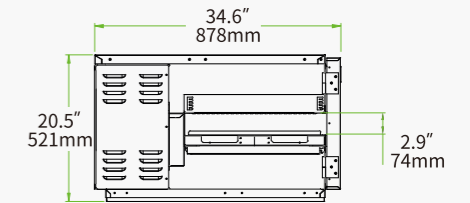

(Left View)

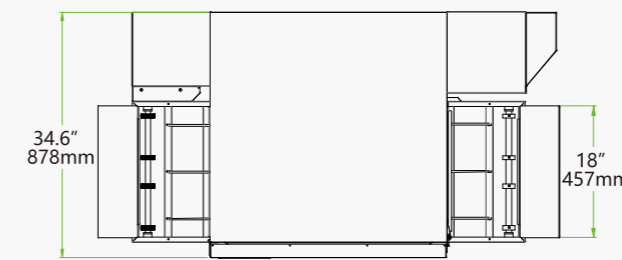

(Top View)

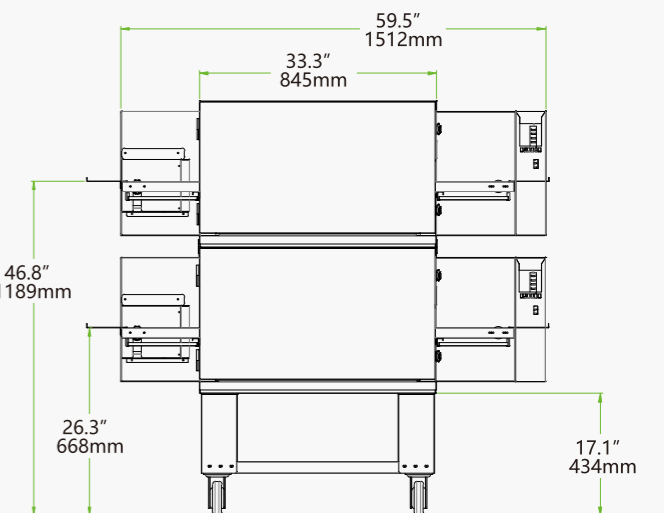

(Stackable)

# Conveyor Oven



H2028

Model H2028	
Setting Time	1.5-20min(adjustable)
Power Consumption	5.5-8.6kW/hr
Max.Temp	400°C
Heating Area(W*L)	20"(480mm)*28"(710mm)
Overall Size	1540*980*480(mm)
Overall (With Extension Tray)	1700*980*480(mm)
Max.Inlet Height	82mm
Floor Space	1.67m <sup>2</sup>
Voltage	380V±10%
Electric Current	23.5A
Power	15.5kW
N.W.	150kg
Suitable for	Middle & large Pizzeria, Western Restaurant
Applied to	Pizza,Snack,Steak,Cheese baked rice Noodles,Dessert

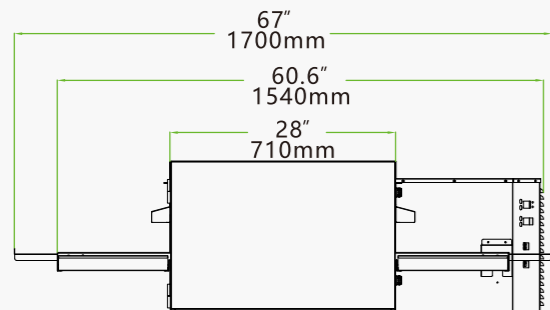

(Main View)

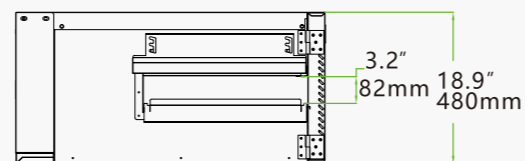

(Side View)

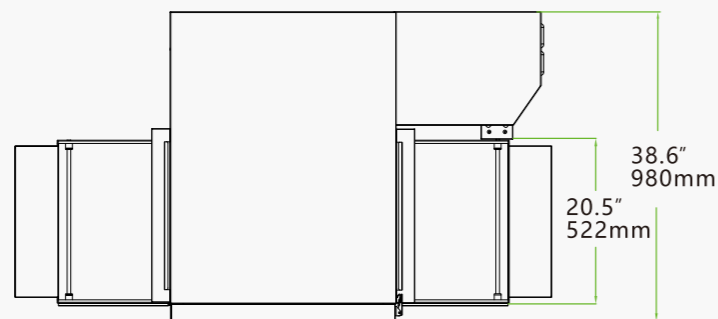

(Top View)



H1832

Setting Time	1.5-25min(adjustable)
Power Consumption	5.8-6.8 kW/hr
Max.Temp	300°C
Heating Area(W*L)	18"(460mm)*32"(821mm)
Overall Size	1817*1155*601(mm)
Overall (With Extension Tray)	1817*1155*601(mm)
Max.Inlet Height	73mm
Floor Space	2.10m <sup>2</sup>
Voltage	380V+10%
Electric Current	22A
Power	15 kW
N.W.	280Kg
Suitable for	Middle & large Pizzeria, Western Restaurant
Applied to	Pizza,Snack,Steak,Cheese baked rice & Noodles,Dessert



H2036

Setting Time	1.5-25min(adjustable)
Power Consumption	9-10kW/hr
Max.Temp	300°C
Heating Area(W*L)	20"(480mm)*36"(914mm)
Overall Size	1524*1092*520(mm)
Overall (With Extension Tray)	1807*1092*520(mm)
Max.Inlet Height	80 mm
Floor Space	1.97 m <sup>2</sup>
Voltage	380V+10%
Electric Current	25A
Power	16.8kW
N.W.	299Kg
Suitable for	Middle & large Pizzeria, Western Restaurant
Applied to	Pizza,Snack,Steak,Cheese baked rice & Noodles,Dessert

## More Electric Models



H2640

Setting Time	2-30min(adjustable)
Power Consumption	11.5-12.5kW/hr
Max.Temp	300°C
Heating Area(W*L)	26"(660mm)*40"(1028mm)
Overall Size	2035*1287*649(mm)
Overall (With Extension Tray)	2239*1287*649(mm)
Max.Inlet Height	85mm
Floor Space	2.86m <sup>2</sup>
Voltage	380V+10%
Electric Current	29.5A
Power	19.2kW
N.W.	410Kg
Suitable for	Middle & large Pizzeria, Western Restaurant
Applied to	Pizza,Snack,Steak,Cheese baked rice & Noodles,Dessert



H3240

Setting Time	2-30min(adjustable)
Power Consumption	17-18kW/hr
Max.Temp	300°C
Heating Area(W*L)	32"(815mm)*40"(1036mm)
Overall Size	2036*1440*649(mm)
Overall (With Extension Tray)	2239*1440*649(mm)
Max.Inlet Height	82mm
Floor Space	3.22m <sup>2</sup>
Voltage	380V±10%
Electric Current	40A
Power	27kW
N.W.	365Kg
Suitable for	Middle & large Pizzeria, Food factory
Applied to	Pizza,Snack,Steak,Cheese baked rice & Noodles,Dessert

## Advantage

### When you own a Bakers Rock Conveyor Oven.

Non-professional chefs, inconsistent practices between new and old employees, complex training.

**Standardized employee operations**

Set oven parameters for different baked foods, adjust temperature and time to fit various operating modes, and offer a one-click professional baking solution.

Do you have high staff turnover? Is it too difficult to find someone who's both competent and affordable?

**Intelligent operation; labor saving**

No professional chefs needed. One-click operation, easy training, reduced labor costs.

Pizza and chicken wings baking at different times? To cook different foods, you have to keep adjusting the temperature and time.

**Cater to diverse food baking needs**

A single oven allows food to be placed at different positions through the openable window, meeting diverse baking needs.

During peak hours, endure high output and fast production without sacrificing quality.

**High capacity; consistent function**

Consistent and stable production ensures reliable food output.

Ovens must stay clean, but cleaning staff and time are limited. Customers want higher-quality baking and greater capacity.

**Low maintenance, easy cleaning**

Easy to operate, easy to clean, simple to maintain.

## Pizza Deck Oven



Single Deck Oven DO-1



Double Deck Oven DO-2



Double Deck Oven DO-2L

### Production Specification

- ◆ **Special heat-resistant pizza stone**  
Uniform temperature, preheating and return temp fast, Max temp up to 400°C
- ◆ **Excellent heat storage**  
High quality continuous baking
- ◆ **Suitable for handmade pizza**  
“Bakers Rock” brand deck oven suitable for handmade pizza so on, digital control, independent top&down Temp control system, easy to operation

Item	Model	DO-1	DO-2	DO-2L
OverallSize(W*D*H)		770*680*310(mm)(included foot 410H)	770*680*565(mm)(included foot 665H)	1145*1050*770 (mm)
InnerSize(W*D*H)		540*510*125 (mm)		710*710*145 (mm)
Range of Temp		0-400 °C		
Upper Tube range of Temp		0-400 °C		
Down Tube Range of Tem		0-400 °C		
Rated Power		3.9 kW	7.8 kW	10.8 kW
Rated Electric Current		17.3A	16.4A	17A
Rated Voltage		220V	380V	380V±10%
N.W.		72kg	125kg	240kg
Warranty		one year		
Suitable For		Cafe, bar Shop, bakery Store, dessert Shop		

## Pizza Dome Oven



Dome Oven P-6/P-4



Countertop Dome Oven P-1

Item	Model	Dome Oven P-6	Dome Oven P-4	Dome Oven P-1
Setting Temp		0-450°C		
Power Consumption		2.5-4 kW/hr	2.5-4 kW/hr	2-3 kW/hr
Baking Area		740*1110(mm)	740*740(mm)	530*510*140 (mm)
OverallSize		1102*1650*1780(mm)	1102*1275*1780(mm)	690*780*595 (mm)
N.W.		600kg	550kg	110kg
Rated Voltage		380V	380V	220V±10%
Rated Electric Current		17A	13.8A	13.6A
Rated Power		11.5kW	7.6kW	3.1kW

### Production Specification

- ◆ **Max Temp up to 450°C**
- ◆ **Imported stone, uniform heat conduction**
- ◆ **Independent top&down Temp control**
- ◆ **Extremely heat preservation, Saving energy**
- ◆ **Bronze appearance and handmade**

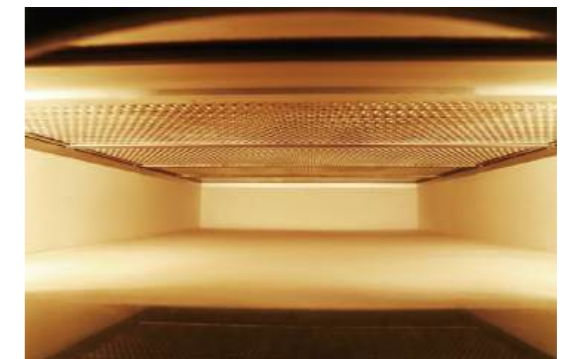

# SHANGHAI PIZZA MASTER COMPETITION



Shanghai International Pizza Masters is dedicated to promoting pizza technology, leading the trend of pizza business and spreading pizza culture, and providing a platform for professional pizza chefs in China to compete, communicate and perform. Currently, there are divisions in Chengdu, Guangzhou and Shanghai, and the top three of the divisions will advance to the finals.



Pizza Elementary Course



## Course Features

- ◆ Start with the basics and get a full grasp of pizza technology
- ◆ Hand tossed and deep pan pizza making
- ◆ Pasta & baked rice & light meal teaching
- ◆ Knowledge of professional pizzeria equipment and ingredients
- ◆ Kitchen planning, Restaurant opening and operation guidance
- ◆ Free retraining within 1 year, new menu open to share
- ◆ .....



Pizza Master Course



## Course Features

- ◆ Pizza culture lecture
- ◆ Chinese and French pizza master teach together
- ◆ Italian style pizza teaching
- ◆ Decode the principle of dough fermentation
- ◆ Sauces and soups matching skills
- ◆ Cultivate innovative research and development ability of pizza chefs
- ◆ .....

# Product Application

## Naples-style Pizza

Temperature: 360°C  
Baking Time: 2min



## Hand Tossed Pizza

Temperature: 245°C  
Baking Time: 4min50s



## Snack

Temperature: 245°C  
Baking Time: 4min50s



## Light Meal

Temperature: 245°C  
Baking Time: 3min



## Gratin

Temperature: 245°C  
Baking Time: 4min50s



## Steak

Temperature: 245°C  
Baking Time: 4min50s



# Our Clients

